

WELCOME to

Saturday Market



MARKETPLACE • COMMUNITY • CELEBRATION

April–November, 2022

30 E. Broadway #124, Eugene, OR 97401 • (541) 686-8885 • fax (541) 338-4248

www.eugenesaturdaymarket.org • info@eugenesaturdaymarket.org

Market's 53rd Season, April 2nd - November 12th

Thank you for your interest in Saturday Market, we hope that all your Market days will be successful! Please review this informational document, and don't hesitate to contact the office, 541-686-8885, if you have further questions.

In this document you will find a detailed explanation of how to get a booth space on Saturday mornings, a Park Blocks map, and the 2022 Membership Agreement. Review these and keep them for future reference.

Selling at Market is easy!

Before you can sell:

- **Submit your membership application** and fee to the Market Office.
- **Have your products screened** and accepted by the Standards Committee. You need to attend an orientation before your products will be screened. Market Orientation and Standards screenings take place at the Market office at 3:30 PM on the first and third Wednesdays of each month from March 2nd through November 2nd, 2022. Orientations and screenings are currently **by appointment only**. Please contact the office at 541-686-8885 to schedule your orientation and screening.

Your typical Market day:

- **Check in at the info booth** no later than 8:30 AM so we know that you are waiting for a space.
- **Wait to hear your name called** in point order. Each day you sell and pay your fees you get one point, which then moves you further up the list.
- **Pick your space** at the Info Booth from the spaces available.
- **Set up by 10:00 AM, sell until 4:00 PM**, rain or shine.
- **Pay your fees** at the Info Booth in the envelope provided. Remember to write your name on the envelope so we can credit you your point for next time.
- **Pack up your booth before** you get your vehicle.
- **Get your vehicle**, load it up, go home, have a nice week, see you next Saturday!

2022 Membership and Space Fees

Annual Membership \$50

Weekly fees:

8'x8' Booth Space	\$15+10%
4'x4' Booth Space	\$8+10%
Strolling Members	\$5+10%

Fire Safety Requirements

If you set up a booth structure at Market you must have a fire extinguisher easily accessible and with an inspection tag dated within the last 12 months. The fire extinguisher must be a 2A10BC or bigger (those little ones don't count). All your roof and side coverings must be fire retardant and there must either be a label on the fabric or plastic, or you must have some kind of documentation with you to prove that it is fire retardant.

Table coverings and wares do not have to be fire retardant. The Saturday Market is subject to unannounced inspections by the Eugene Fire Marshal.

About New Product Screening

All products must be screened and accepted by the Standards Committee before being sold at Saturday Market. The products are reviewed according to the general craft areas as defined in the Member Information Handbook, available online or in printed form at the Market office.

Combined Market Orientation and Standards screenings take place at the Market office at 3:30 PM on the first and third Wednesdays of each month from March through November.

The general craft guidelines are:

1. Items must be handmade, grown or gathered by the Market Member, or a member of their immediate family living in Oregon.
2. The Member contribution to a finished product must outweigh the contribution of any commercial components used in the making of that product. Skills in craftsmanship, as well as creative abilities, ingenuity and design skills are examples of Member contribution.
3. The product must meet basic expectations of product life, function, and safety.

Park Blocks Parking

A high priority of the Board of Directors of the Saturday Market is assuring that parking around the Park Blocks stays respectful, safe, and organized. There are over 200 Members that need to load in and out on an average Saturday. Vehicles can be unloaded on East, West, and South Park Streets, and on 8th and Oak Streets before 9:30 AM and after 4:00 PM.

- There is a 20-minute parking limit at the Park Blocks when loading and unloading. After unloading your vehicle, please park your vehicle promptly and then come back and set up your booth.
- Do not park on 8th, Oak St, or any of the Park Streets when waiting for booth assignment in the morning.
- Do not block access ramps while loading/unloading, folks need to use them!
- Parking is free all day in either of the city parking structures at the Arcade at 8th and Willamette, and at the Overpark at 10th and Oak St. Do not leave valuables in your vehicle, as thefts do occur.
- Parking spaces around the Downtown Park Blocks are to be used by Market's customers. Market Members are prohibited from using them except for loading and unloading.

It is imperative that you follow these parking requirements. Violations may be considered a breach of the membership agreement and can result in disciplinary action. To let Market management know about specific parking violations fill out a parking complaint form, available at the Info Booth.

Food Booths

Currently there are no openings for a new food booth in the International Food Court. When an opening occurs, we advertise the opening in local papers, and then the Standards and Food Court Committees starts the process of choosing a new food booth.

Getting Involved with Your Market

Saturday Market is a Member run organization that relies on Member input for guidance and inspiration. The Board of Directors, Standards, Holiday Market, and Sustainability meet monthly, and Food Committees meet as scheduled. Market Members are always welcome to join committees or just sit in to see how the Market works behind the scenes. Committee meetings are listed in each week's Market newsletter, and on the Market calendar on our website.

Other Market Events

Your 2022 membership allows you to sell at the other Market events during the year. These events include Tuesday Farmers' Market (May-October) and Holiday Market (Mid-November-Christmas). Each of these events has their own separate fees, applications, deadlines and booth allocations. Holiday Market information is automatically sent to current Members in mid-July. Information about other Market events is available at the Market office.

Connecting with Market

During the Market season we publish a weekly newsletter, available at the Info Booth and on the website, which includes current Market news, Market Family news, free "Unclassifieds", (a great place to look for used booths, vehicles and other stuff), current meeting schedules and other info.

Our website, www.eugenesaturdaymarket.org, has lots of information for customers and Members. Here you can find the Member Information Handbook, plans for the standard wooden Market booth, Market history, Member listings, entertainment schedule and more.

You will have access to our Member Portal. The Portal allows you to upload pictures, add business description and links to your social media or websites. Your profile is listed in our searchable Artisan Directory that is also integrated with our Weekly Live Map.

If you're a Twitterer or Instagrammer, you can follow us @saturdaymarket. Like us on Facebook: www.facebook.com/eugenesaturdaymarket. There is also a private Facebook group, search for "Eugene Saturday Market Members" and hit the "ask to join" button.

How to get a Booth Space on Saturday

Saturday Morning Booth Allocation

You must be a current Member of Saturday Market to choose a space and sell at the Market. To become a current Member, you must complete the membership form, pay your membership fee, attend an orientation, and have your products screened and approved by the Standards Committee in advance of the first Saturday that you would like to sell. The combined Market Orientation and Standards screenings take place at the Market office at 3:30 PM on the first and third Wednesdays of the month, March–November. Orientations and screenings are currently **by appointment only**. Please contact the office to schedule your orientation and screening.

To sell on Saturday, check in at the Information Booth and have your name entered on the Waiting List. You can sign in between 7:00 AM and 8:30 AM. You must sign in at the Info Booth in person. The Market reserves the right to refuse sign-ins after 8:30 AM. At 8:30 AM any unclaimed reserved spaces are declared vacant, and the Information Booth staff begins

to assign non-reserved spaces and vacant reserved spaces in the order in which Member's names appear on the Waiting List. The Waiting List is arranged in point order determined by the number of times Members have sold at Saturday Market during the current season, plus points for past participation. (See detailed point description below.) Point ties are broken by computer assigned random numbers, different random numbers are assigned each week, so signing in early does not give you an advantage.

You must be present at the time your name is called. Any Member not present at that time may be reassigned to the bottom of the list for that day. As your name is called, step up to the Information Booth and quickly choose your daily space. You can then proceed to set up your booth. You should finish setting up by the Market's opening at 10:00 AM. If space assignments run late, at least get all of your equipment into your space by 10:00 AM.

Saturday Market cannot guarantee that spaces will be available for all Members wishing to sell on a given Saturday. Members who sign in on time and wait through the booth assignment process and are ready and willing to sell but are not assigned a booth due to lack of space will receive one selling point for the day. No fee is charged.

Strolling Members should sign in between 10:00 AM and 11:00 AM, and must stay until at least 3:00 PM to receive a point.

Pay Fees to Get Your Point

At the time of booth assignment, you will receive a payment envelope indicating your space number. To ensure that your payment gets credited properly, be sure to write your name on the envelope. Fees are due at the end of each selling day, and can be paid between 4:00 PM and 4:30 PM at the Information Booth, during the week at the Market office, or by mail. Fees not paid by Wednesday at noon are considered late. **You will not receive your daily point until your fees for the day are paid.** If you pay after Wednesday, your point will not be added until after the next Saturday. If your fees are 30 days late, a \$5 fee will be applied to the balance. If fees are 60 days late, \$10 is applied to the balance. Members with multiple past due fees are encouraged to meet with the General Manager to set up a payment schedule.

About Points

Each Saturday, vacant and non-reserved booths are assigned to non-reserved Members using a point system that is based on the number of days a Member has sold during the current Market season. For details, see the next page "How Eugene Saturday Market Points Work."

About Reserved Spaces

Booth spaces at Eugene's Saturday Market are reserved each year in March through a priority system based on points accumulated during the prior season. (April through mid-November). It may take up to a full season of regular selling to get enough points to get a reserved space. Members who would like to get a reserved space on the Park Blocks must fill out a "Wish List." Sometimes a few reserve spaces become available mid-season and are assigned. In this case, the opportunity is announced in advance in the weekly Newsletter.

How Eugene Saturday Market Points Work

Membership Points are your points for continuous years of Membership. For your first five years of continuous Membership, you get one point at the end of the year. After the first five years, you get one more point for each additional five years of Membership. At the end of five years, you have five points. At the end of 10 years, you have six points, and so on. If you do not renew your Membership each year, then your points are lost. These points are used in the other point calculations that follow. The maximum Membership Points in 2022 is 11.

Waiting List Points are your "place in line" as you wait for a booth at Saturday Market. During the Saturday Market season, we add one Waiting List Point for each Saturday Market where you sell and pay your fees. You receive your point after you pay your fees. If you pay your fees by Wednesday, then you will have the point added to your total for the next Saturday. Point ties are broken by computer assigned random numbers. Different random numbers are assigned each week. Waiting List Points are recalculated at the beginning of each Market season. We add your Membership Points plus 1/10th of the number of Saturday Market Points you earned last year (the Market days you paid your fees for prior to 12/31.) There were 33 Saturday Markets, 3 Twilight Markets and 13 Holiday Market days in 2021. There will be 33 Markets in 2022. The most points a Member can start the 2022 season with is 15. The most they can have at the end of the season is 48.

$$\begin{array}{r} \underline{\hspace{2cm}} \text{Membership Points (max 11)} \\ + \underline{\hspace{2cm}} \text{2021 Saturdays and Twilights (max 36) divided by 10, rounded up (max 4)} \\ = \underline{\hspace{2cm}} \text{2022 Starting Waiting List Points} \end{array}$$

Wish List Points are your "place in line" for a reserved booth space. Wish List Points are your Membership Points plus the number of Saturday Markets you sold at in the previous season. Remember, only Saturday Markets that you have paid for by the end of the year count towards this calculation. Point ties are broken by date received. There were 33 Saturdays and 3 Twilight Markets in 2021. The maximum number of Wish List Points is 47.

$$\begin{array}{r} \underline{\hspace{2cm}} \text{Membership Points (max 11)} \\ + \underline{\hspace{2cm}} \text{2021 Saturdays and Twilight Markets (max 36)} \\ = \underline{\hspace{2cm}} \text{2022 Wish List Points} \end{array}$$

Holiday Market Points are your "place in line" to pick a space for this year's Holiday Market. They are calculated at the end of the previous season. Holiday Market Points are made up of your Membership Points, plus one point for each Saturday Market attended during the previous season plus one point for each Saturday Market attended in October and November of the season previous to the last season, plus one point for each two days attended during the last two Holiday Market seasons. As always, points are only awarded for Market days that have been paid for by the end of the year. Maximum 2022 Holiday Market points is 60-65.

$$\begin{array}{r} \underline{\hspace{2cm}} \text{Membership Points (max 11)} \\ + \underline{\hspace{2cm}} \text{2021 Saturdays and Twilight Markets (max 36)} \\ + \underline{\hspace{2cm}} \text{2020 Oct/Nov Saturdays (max 6/11)} \\ + \underline{\hspace{2cm}} \text{0 2020 Holiday Markets divided by 2 (max 0)} \\ + \underline{\hspace{2cm}} \text{2021 Holiday Markets divided by 2 (max 7)} \\ = \underline{\hspace{2cm}} \text{2022 Holiday Market Points} \end{array}$$

Booth Holder of Record (reserve space) status for Holiday Market is given to Members who occupied a Holiday Market space for at least four of the weekend blocks in the previous year and who have at least 50% of the Holiday Market points possible as calculated above. *In 2022, you need at least 30-35 to keep your space.*

Updated 2/8/2022, Created 2/3/2015

Saturday Market Tent and Umbrella Use Policy

Accidents at open-air markets often involve wind-blown tents and umbrellas. To provide a safe Market experience for our customers, Members and their wares, we require all Saturday Market Members to adhere to the following rules for both tent and umbrella use.

1. Strong gusts can come up without warning at any time; therefore, you must be sure to completely secure your tent/umbrella as soon as you set it up and take down your tent/umbrella as soon as you remove its weights at the end of the day. It is vitally important that you do NOT let yourself be interrupted by anything in the middle of this process. A partially-secured tent/umbrella can be as dangerous, if not more dangerous, than an unsecured tent/umbrella.
2. All pop-up style tents (booths) and umbrellas at Eugene Saturday Market shall be weighted to withstand wind gusts.
 - Each 8'x8' pop-up tent shall have a minimum of 25 lbs. attached to each tent leg.
 - Each 4'x4' pop-up tent structure shall have a minimum of 25 lbs. attached to at least two legs, and they must be positioned diagonal to each other.
 - Umbrellas shall have a total of 50 lbs. at the base, including the weight of the stand.
 - Water-filled plastic jugs or other weights encased in plastic are not acceptable.
 - Tent weights must be contained within the booth area, not in the customer walkway.
 - It is strongly suggested that traditional wooden booths and metal pole-frame booths be weighted as well. This may become a requirement in the future.
3. Weights shall be secured in a manner that prevents hazards:
 - Weights shall not cause a tripping hazard
 - Weights shall be tethered with lines that are clearly visible
 - Weights shall be securely attached
 - Weights should be on the ground (NOT above people's heads)
4. Sidewalls attached to ANY Member booths (pop-ups, wooden and metal pole-frame) should have an opening of several inches at both the top and bottom of the walls to allow wind to pass through the booth rather than create the "sail effect".

Fig. A After filling sand bags to 25-30 lbs, lay bag down next to canopy leg and insert the quick release pin through the grommet on the strap.

Fig. B Pass tent pin through hole in the leg of the canopy and stand bag upright. Fasten middle buckle strap around leg of canopy. Repeat for each leg of canopy.

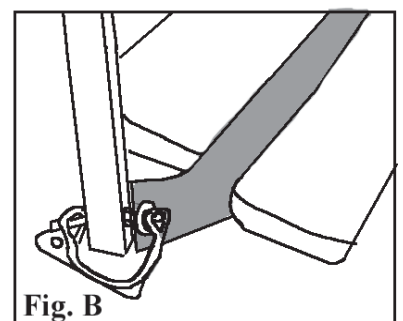
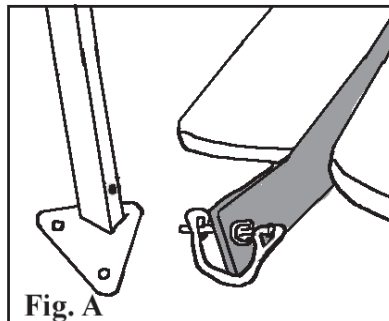

2022 SATURDAY MARKET MEMBERSHIP AGREEMENT
BETWEEN: The Saturday Market, an Oregon non-profit corporation (Saturday Market)
AND: Member of Saturday Market (Member)

RECITALS

- A. Saturday Market grants Member a non-assignable right to use and occupy, during the time set forth below, a market space designated by the Saturday Market.
- B. The Market space will be used for the sole purpose of sale of merchandise created by Member to the public.

AGREEMENT

- 1. **Annual Membership Fee.** Member agrees to pay to Saturday Market an annual membership fee of \$50.00 upon the signing of this agreement.
- 2. **Compliance with Saturday Market Guidelines.** Merchandise must meet the Saturday Market Guidelines which includes the right to erect a structure to protect and display such merchandise on the market space.
- 3. **Selling Fees.** Member may use and occupy the market space designated by the Saturday Market and agrees to furnish everything necessary for Member's marketing venture. Member shall pay to the Saturday Market a booth fee as published in the most recent Member Information Handbook plus 10% of gross sales for the use of market space on the Park Blocks. Gross sales shall include orders taken. The agreement does not address fees for Holiday Market which will be set forth in separate document.
- 4. **Reserved Spaces.** Reserved booth market spaces on the Park Blocks are assigned through the point system. Applications for a reserved market space may be made by filling out and turning in a "Wish List Request." Attendance one time per month in the reserved market space and a minimum of twelve times per season is required for all reserve holders. Reserved market spaces not claimed by their reserve holders by 8:30 a.m. on the day of Market will be made available to other Market Members. Reserved booth market spaces are reserved on seasonal basis, and paid for monthly (\$160/season at \$20/month min) or seasonally (\$150/season) by those Members who have been assigned a reserved market space. For each market day hereafter that Saturday Market grants use of a market space to the Member, the terms of this agreement shall be effective. Saturday Market shall have no obligation to hereafter grant such a permit.
- 5. **Covenants of the Parties.** The following shall be binding upon the parties:
 - 5.1 This permit is valid only for the 2022 Market season (April 2022-March 2023).
 - 5.2 Saturday Market intends to and expects Member to comply with all local, state, federal and special statutes or ordinances regarding public health, safety and welfare, and to use market space in a reasonable and non-offensive manner and subject to rules and regulations of Saturday Market in effect on date of use.
 - 5.3 Member may construct a structure in accord with the size and safety specification as found in the current Saturday Market Member Information Handbook. Member shall, at all times, ensure that such structure shall not encroach upon or obstruct public walkways or open space areas. Member shall promptly remove any offensive structure upon request of Market staff.
 - 5.4 Member shall not use any bottled gas, electrical devices, or hazardous materials without prior approval by Saturday Market. Member shall not injure or in any way deface the Market premises and shall not cause or permit anything to be done whereby such premises may in any manner be injured or defaced. Member shall indemnify and hold Saturday Market harmless from all damages for injury to the premises caused or permitted by the Member.
 - 5.5 Saturday Market assumes no responsibility whatsoever for any Member property placed upon the Market premises. Member agrees to indemnify Saturday Market against all loss and damage to the Member's property sustained by reason of occupancy by Member of the premises or any portion hereof.
 - 5.6 Should Member at any time occupy the premises in a manner contrary to this agreement or any rules and regulations of Saturday Market, or in any manner which is hazardous or offensive to the public or other Members, upon request of staff, Member shall immediately cease such conduct. Failure to immediately conform ones' conduct as requested shall be cause for revocation of this permit. Upon revocation, Member shall promptly vacate the premises. Upon failure to vacate, Saturday Market is relieved and discharged from all loss of damage occasioned by such removal, and shall not be responsible for safekeeping of property so removed.

5.7 Failure or delay of Saturday Market to require performance of any provision of this agreement shall not limit the right to later enforce that or any other provision.

5.8 If suit or action is brought to enforce any terms of this agreement, the prevailing party shall be entitled to recover from the party attorney's fees and related expenses at trial or on appeal.

5.9 This agreement by reference includes the provisions contained within the current Member Information Handbook and related Saturday Market literature. Such provisions may be periodically revised by the Saturday Market Board of Directors during the market season. It is the responsibility of Member to be aware of and comply with all Saturday Market rules and regulations.

6. Indemnification.

6.1 Liability. Member agrees to indemnify, defend, and hold Saturday Market, its agents and employees, harmless from any claim for a personal injury which is not covered by Saturday Market's general liability policy including but not limited to any claim made for personal injury for a defective good or service sold or provided by Member, whether or not such claim is well founded.

6.2 Tender of Defense. In the event that a claim is made against Saturday Market which is covered by the provisions above, Saturday Market agrees to give written notice to Member, and tender the defense of the claim to Member.

6.3 Reimbursement for Defense Costs. In the event that Saturday Market gives notice to Member and tenders defense of a claim covered by paragraphs 3 and 4 above, and Member fails or refuses to accept the tender, Saturday Market may retain its own attorney to represent its interests with respect to the claim, and Member agrees to pay Saturday Market's defense costs, including reasonable attorney fees.

6.4 Covenant Not to Sue. Member covenants not to sue Saturday Market, its agents or employees for contribution or indemnity for any claim made against Member arising out of an injury caused by an act or omission of Member or its agents which is not covered by Saturday Market's general liability policy, including but not limited to any claim made for personal injury for a defective good or service sold by or provided by Member.

6.5 Nondiscrimination. Neither party shall discriminate as to race, creed, color, sex, religion, sexual orientation, age, nationality, or marital status.